

IDEAL LOGIC+ 18 BOILER EXTERNAL

MANUFACTURED BY:

ideal
HEATING

The Logic+ 18 **Condensing** System Boiler provides excellent energy saving, with ultra quiet operation.

- Made in the UK
- Custom designed external case
- 1:4 Modulation rate
- Built in Frost Protection
- Large backlit LCD display
- Aluminium Silicon Heat Exchanger
- Light weight and compact design
- Quiet operation
- User friendly control panel



10 YEAR*
WARRANTY



MODELS

Logic+ 18kW System

MEASUREMENTS

902 (H) x 425 (W) x 312 (D) mm

MAGNACLEAN FILTER



WATER TREATMENT



ADDRESS

Waterloo NSW 2017

PHONE 0467 572 039

info@hydronicnsw.com.au

www.hydronicnsw.com.au

General Data		18 System	
Gas Supply		Natural Gas at 1.13kPa	
Gas Supply Connection		1/2"	
Flow Connection		3/4"	
Return Connection		3/4"	
Flue Terminal Diameter	mm	100	
CO2 Content (± 0.7)	Max. CH	9.2%	
	Min. CH	8.6%	
Maximum Working Pressure (Sealed Systems)	kPa	250	
Electrical Supply		230 V ~ 50 Hz	
Power Consumption	W	78	
Min. thermostat cable size		1mm twin active	
Water Content	Litre	1.2	
Height	mm	902	
Width	mm	425	
Depth	mm	450	
Packaged Weight	kg	46.8	
Installation Weight	kg	43.2	
Performance Data		Min	Max
Boiler output - Mean 70°C	kW	4.8	18.0
Boiler output - Mean 40°C	kW	5.1	19.1
Gas Consumption	MJ/h	18.5	71.43
Boiler Efficiency	%	91.1	

CLEARANCES

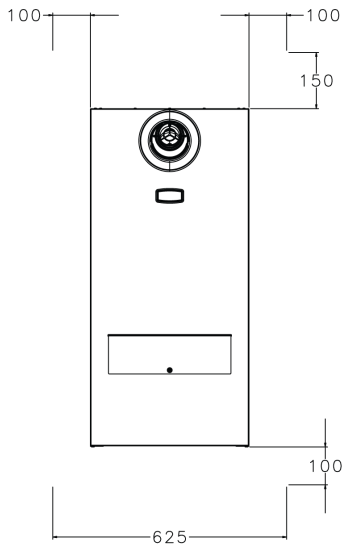

BOILER DIMENSIONS

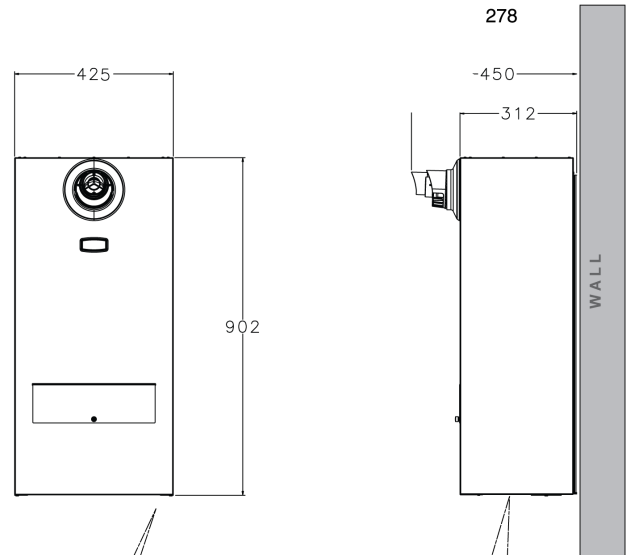

Water Connections and Gas Connection

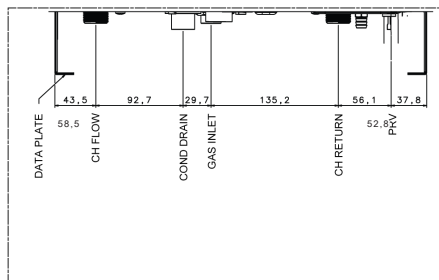

Underside View - Pipe Dimensions to Wall

